

FOG CANNONS WLP 700 WITH ARMS

Technical Data	Skid
Jet length	60/70 m
Dimensions (Length x Height x Width mm)	3156 x 2840 x 1200
Full Height - With Arm Extended	5617 mm
Weight kg	1565 kg
Site Mobility	Skid with adjustable legs
Rotation angle	Up to 340° programmable
Tilt angle	Electric from -20° to +45°
Noise levels	< 85 dB(A)
Minimum pressure	1 Bar
Rings of nozzles	3
Nozzles per ring	50
Washable stainless-steel filter	Yes
Jet diameter	30 m
IP degree of protection	IP 55
Power supply	
Power Supply	63A 5P Plug
Total electric power installed	20 Kw
Fan power	11 Kw
Water pump power	7.5 Kw
Amperage	36 Amp
Features	
Remote control	Standard
Rotation system	Standard
External activation (client or supplied)	Option
Onboard Weather station onboard control	Option
Solenoid valve at water filter inlet	Standard
High-efficiency electric pump	Standard
Solenoid valve for each nozzle ring	Standard
Tilt with servo actuator	Standard
Switchboard with PLC for automation	Standard
Water Consumption	
Nozzle Types	Ring 1 with 0.3 LPM nozzles Ring 2 with 0.6 LPM nozzles Ring 3 with 0.95 LPM nozzles
Water discharge pressure	12 Bar
Water consumption	21 - 125 L/min

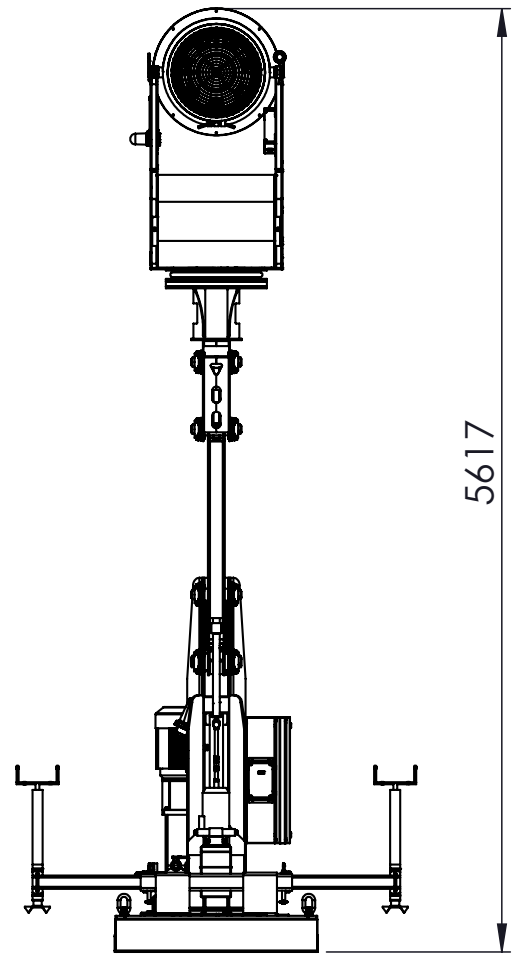

Key Features

- Suitable for working in extreme conditions.
- High efficiency stainless steel multistage water pump.
- Mounted on a steel base with tyne pockets or trailer for easy positioning.
- High efficiency submersible pump.
- Variable water flow rate.
- Stainless steel water filter
- Stainless steel nozzles
- Remote activation by remote control
- Ready for PLC integration

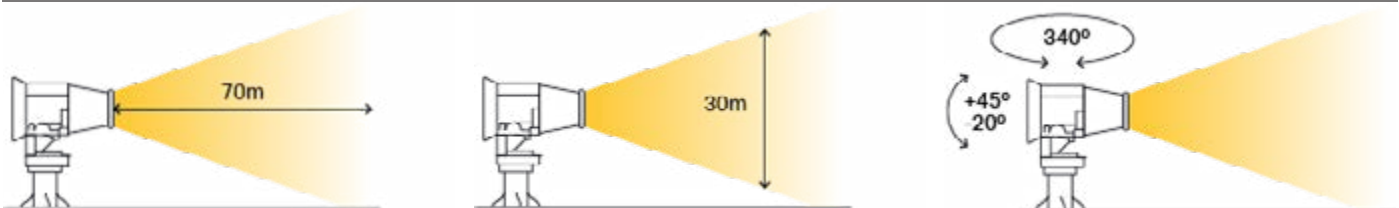
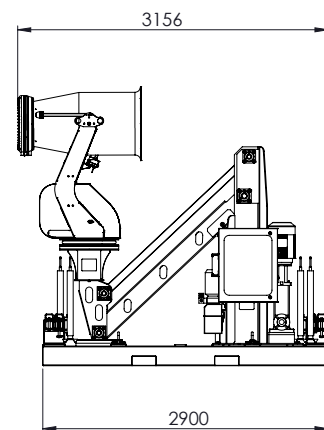

FOG CANNONS WLP 700 WITH ARMS

